

Backing Rings FRP

by SMC Hot Pressing

Resin Vinylester / off-white colour

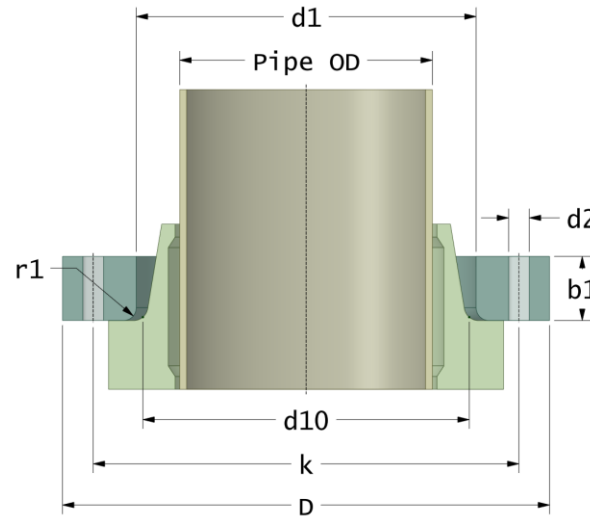

ROTEC
Composite Group

with drillings according to

EN1092 PN16

suitable for **GRP stub flange**

January 2025

Page 1/2

DN	Pmax	D	d1	d10	r1	k	Holes	d2	b1	Article Number	
(mm)	(bar)	(mm)	(mm)	(mm)	(mm)	(mm)	(no.)	(mm)	(mm)	(code)	
15	16	98	34	33	3	65	4	14	15	BRP-15-34-16/16	
25	16	116	51	50	3	85	4	14	15	BRP-25-51-16/16	
32	16	140	59	58	3	100	4	18	16	BRP-32-59-16/16	
40	16	154	69	68	3	110	4	18	18	BRP-40-69-16/16	
50	16	164	83	82	4	125	4	18	18	BRP-50-83-16/16	
65	16	184	96	95	4	145	4	18	20	BRP-65-96-16/16	
80	10	200	112	111	4	160	8	18	23	BRP-80-112-10/16	
80	16	200	112	111	4	160	8	18	28	BRP-80-112-16/16	
100	10	228	134	133	5	180	8	18	25	BRP-100-134-10/16	
100	16	228	134	133	5	180	8	18	30	BRP-100-134-16/16	
125	10	254	161	160	5	210	8	18	28	BRP-125-161-10/16	
125	16	254	161	160	5	210	8	18	34	BRP-125-161-16/16	
150	10	284	189	188	5	240	8	22	34	BRP-150-189-10/16	
150	16	284	189	188	5	240	8	22	40	BRP-150-189-16/16	
200	10	342	238	237	6	295	12	22	38	BRP-200-238-10/16	
200	16	342	238	237	6	295	12	22	48	BRP-200-238-16/16	

Backing Rings FRP

by SMC Hot Pressing

Resin Vinylester / off-white colour

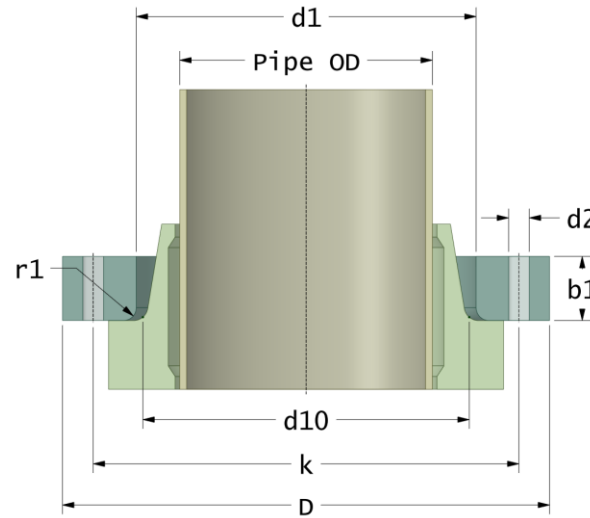

ROTEC
Composite Group

with drillings according to

EN1092 PN16

suitable for **GRP stub flange**

January 2025

Page 2/2

DN	Pmax	D	d1	d10	r1	k	Holes	d2	b1	Article Number	
(mm)	(bar)	(mm)	(mm)	(mm)	(mm)	(mm)	(no.)	(mm)	(mm)	(code)	
250	10	405	294	293	6	355	12	26	42	BRP-250-294-10/16	
250	16	405	294	293	6	355	12	26	54	BRP-250-294-16/16	
300	6	458	344	343	6	410	12	26	38	BRP-300-344-06/16	
300	10	458	344	343	6	410	12	26	48	BRP-300-344-10/16	

Larger diameters (up to DN 3600) or higher pressure ratings; see BR type (by RTM)